

User friendly pulsation analysis tool for your API 618 and API 674 studies

Are you a pipe stress engineer or acoustic flow engineer who needs to assess the impact of pressure pulsations on your piping system?

BOSpulse might be the tool you are looking for. BOSpulse® is a software solution for performing pulsation analyses of piping systems involving reciprocating pumps or compressors. It is an intuitive and effective tool for studying periodic pressure pulsations in piping systems and for comparing those pressure pulsations with the allowable pulsation amplitudes stated in the API 618 and API 674 standards.

MODEL BUILDING IS SIMPLE

The model building procedure used in BOSpulse is intuitive, with a graphical user interface that includes an interactive 3-D representation of the piping model. The model is created by defining nodes and elements.

A collection of special flow elements enables you to build realistic models of piping systems. These flow elements include reducers, orifices, valves, vessels, storage tanks, and reciprocating pumps and compressors. A BOSpulse model can also include supports and structural steel.

This means that you only need to build one model that can be used both for flow and structural analyses. This greatly reduces the need to build and maintain two different models in different software applications.

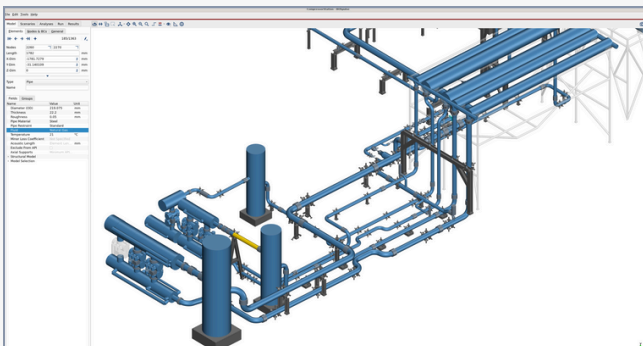

IMPORT AND EXPORT FEATURES

Because BOSpulse piping models are 3-D models, exchanging models with pipe stress packages is relatively straightforward. In particular, BOSpulse provides a bi-directional interface with Hexagon's pipe stress analysis software CAESAR II®, eliminating redundant work processes and thereby improving the quality of both pipe stress and fluid flow calculations. BOSpulse can also import models from various other file formats, including Piping Component Files (PCF) model files, and supports XML configurations from the Ariel Performance Program. In addition, the geometry of a BOSpulse model can be updated from an external model.

FEATURES

- API 618, API 674, and custom code checks
- Pressure pulsation assessment
- Shaking force assessment
- Accurate time domain and frequency domain solvers
- Fast simulations using parallel processing
- Component database for materials, liquids, gases, equipment, and pipe schedules
- Intuitive user interface
- Interactive 3-D viewer
- Compressor and pump models
- Structural solver interface
- CAESAR II® import & export
- Extensive post-processing capabilities
- Customizable reports
- Versatile and powerful scenario management

APPLICATIONS

- Reciprocating compressor and pump plants
- Positive displacement devices
- Vibration root cause analysis
- Design of compressor bottles
- Accumulator sizing
- API 618 and API 674 design

STRUCTURAL SOLVER INTERFACE

BOSpulse includes a structural solver interface that makes it possible to perform a mechanical response study without leaving the BOSpulse interface. This requires the availability of a supported structural solver such as ANSYS. If a supported structural solver is not available, you can export the calculated shaking forces to packages such as Hexagon's CAESAR II or Bentley's AutoPIPE to continue the analysis.

API 618 AND API 674 CODE COMPLIANCE

Pressure pulsation amplitudes and shaking forces can be checked against the design limits stated in the API 618 or API 674 standards and against custom limits. The API 618 and API 674 design limits are defined automatically based on the piping layout and you are provided with many post-processing options to evaluate conformance with the code. In addition to that, BOSpulse provides support for performing parameter studies in which any model parameter can be varied.

ACCURATE TIME-DOMAIN AND FREQUENCY-DOMAIN SOLVERS

With BOSpulse you have a choice between a time-domain and a frequency-domain solver. While traditionally the time-domain solver has been considered to be more accurate, the frequency-domain solver has seen significant improvements that bring its accuracy practically on par with the time-domain solver. As a consequence you can speed up many pulsation analyses dramatically by switching from the time-domain to the frequency-domain solver.

FLEXIBLE POST-PROCESSING CAPABILITIES

The powerful graphical interface of BOSpulse presents you with an instant overview of all the pulsation results. In this interface you can quickly point and click, or use the toolbar sliders to identify if there are any critical areas. BOSpulse also supports multiple types of graphs to show results in the time or frequency domain, and fully customizable text reports. User preferences can be saved for use in subsequent simulations for consistent comparisons of results.

EXPERIENCED AND RAPID SUPPORT

Dynaflow Research Group (DRG) uses BOSpulse extensively for pulsation analyses within our own consulting projects. Should you need any advice on how to get the best out of the software, the specialists of DRG are always available to provide the best possible support. In addition, the software team is always working to add additional features, often based on customer suggestions, to make your analysis even easier.

ABOUT DYNAFLOW RESEARCH GROUP

Dynaflow Research Group (DRG) specializes in the advanced end of the engineering spectrum around the themes of Flow, Vibrations/pulsations, Mechanical and Fiberglass Engineering. In these fields DRG provides engineering consulting services, software and training courses.

The engineers in our team at DRG regularly work on projects across a multitude of technical disciplines. We have a flexible working structure, which means that we can help you immediately. At DRG we are creative thinkers and we work closely together with you, to develop practical and economical solutions.

software@dynaflow.com
www.dynaflow.com



**LEARN MORE ABOUT
BOSPULSE**

**DYNAFLOW
RESEARCH
GROUP.**

LICENCE OPTIONS

You can choose between time-limited licenses (three months or one year) and perpetual licenses, and you can choose between cloud-based network licenses and hardware-based local licenses. A cloud-based license requires a working internet connection in order to use the software.

A hardware-based license involves the use of a USB dongle that must be connected to the computer on which the software is used. Note that a perpetual license implies a hardware-based local license. Also, note that BOSpulse will keep working in demo mode when your license has expired. This means that you can still open your models and view the results.

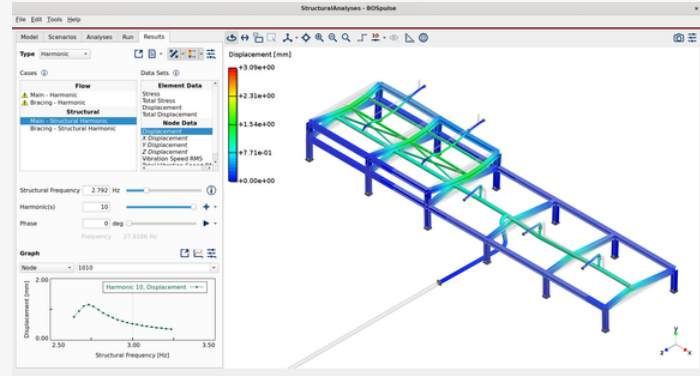
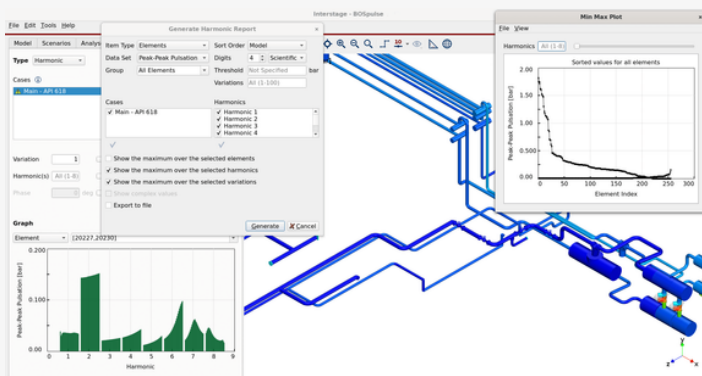
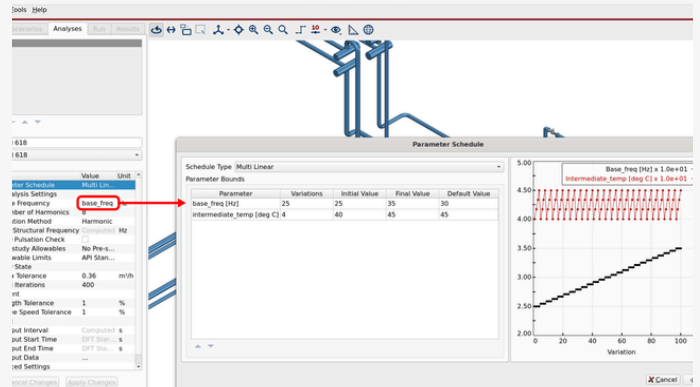
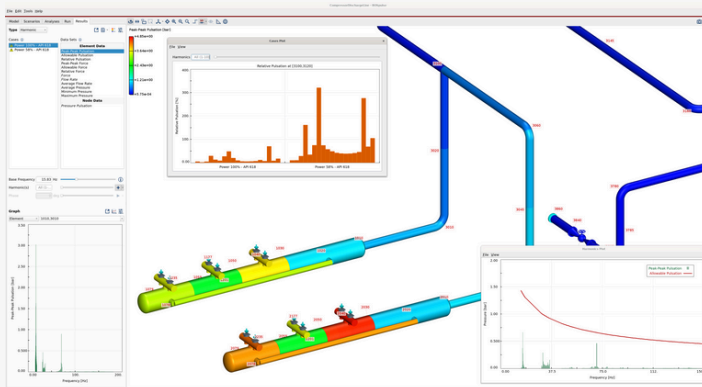

FEATURE OVERVIEW

Available Features	
Model builder (number of items not limited)	✓
Model importer (CII, Epanet, PCF, etc)	✓
Scenario builder	✓
3-D piping models and interface	✓
Model properties viewer	✓
Reciprocating Compressors	✓
Reciprocating Pumps	✓
Fluid, material and equipment database	✓
Compressible fluids (gasses)	✓
Incompressible fluids (liquids)	✓
Time domain and frequency domain solvers	✓
Run analyses on multiple cores	✓
Definition of custom data sets	✓
Parametric analysis	✓
Pressure and steady flow analysis	✓
Pressure pulsation analysis	✓
API 618 and API 674 code checks	✓
Shaking force assessment	✓
Customizable reports	✓
Bill of Quantity reports	✓
Cavitation time prediction	✓
Combined fluid-structure analysis	✓
User-defined code checks	✓